

## STANDARD COMPACT SCALE

## DATA BRIEF

Models XRW



(See chart on back of page for dimensions and ordering number.)

The **METTLER TOLEDO Xpress™ XRW Standard Compact Scales** are designed to handle the job in a wide range of manufacturing and food service applications! A **fast display update rate** and the **waterproof enclosure** allows **portioning of meat, poultry, fish or frozen food** in wet/damp environments. The **high precision load cell** makes the XRW the ideal scale for **mixing of flavors** and spices as well as chemical ingredients. Bakeries will appreciate the **patented dustproof sealing** while **checkweighing dough** before packaging. Consider the potential—restaurants, retailers and “Mom & Pop’s” can enjoy the XRW’s speed and versatility for weighing anything from tea and coffee to cheese, fruit, mushrooms—you name it! The XRW is available as single display or dual display version.

### APPLICATIONS

- Food processing
- Retail and grocery
- Portion control
- Packaging
- Checkweighing

### STANDARD FEATURES

- Select lb, g or oz
- Super fast weigh result
- Rechargeable Battery (included)
- AC Adapter (included)
- IP65 / NEMA 4X protection (dual display version only)
- Over/Under weighing feature
- Audible alarm
- Removable stainless steel platter
- Four level brightness adjustment
- Battery/Power saving
- **Single display or dual, user and customer displays** versions available



*The Dual Display XRW has a second display on the back of the scale that is conveniently visible for your customer or co-worker.*

### Display

14 mm height, 6 digit red LED,  
Dual or Single display  
1/6000 display resolution (1/3000 approved)

### Cursor Indications

Gross zero, Net, Charging, Battery, Weight units,  
Over/Under

### Keyboard

4 touch keys, tactile and tone feedback

### Basic Functions

Zero, tare, on/off, over/under

### Platter

7" x 9" stainless steel

### Scale Dimensions

12.2" x 9" x 5"

### Units

lb, g, oz

### Battery

Rechargeable lead-acid, 6V/5Ah, sealed

### Adapter

9V/500mA

### IP Protection

IP65 / NEMA 4X (dual display version only)

### Tare Range

100%

### Overload Stop

150% FS

### Operating Temperature

-10°C to +40°C (10° to 104°F)

10 to 90% humidity, non-condensing

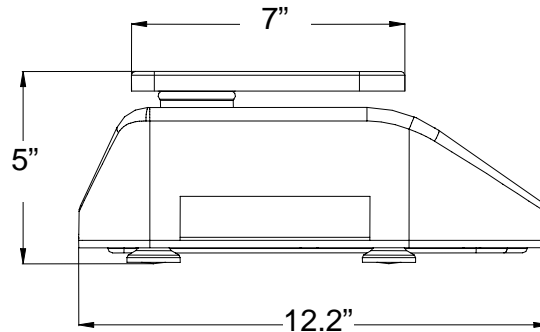
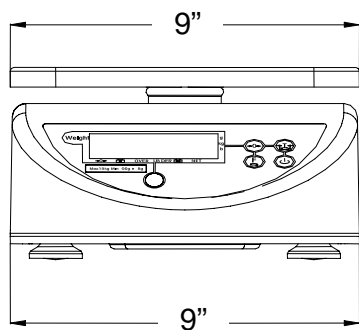

### Standard Compact Scale – Dual Display Version

Item #	Model	Capacity [lb]	Resolution [lb]	Platter Size ["]	Shipping Information			
					L ["]	W ["]	H ["]	WT [lb]
71207643	XRW11-1220	3	0.001	7 x 9	15.0	11.6	7.5	12.6
71207644	XRW11-2220	6	0.002	7 x 9	15.0	11.6	7.5	12.6
71207645	XRW11-3220	15	0.005	7 x 9	15.0	11.6	7.5	12.6
71207646	XRW11-4220	30	0.01	7 x 9	15.0	11.6	7.5	12.6

### Standard Compact Scale – Single Display Version

Item #	Model	Capacity [lb]	Resolution [lb]	Platter Size ["]	Shipping Information			
					L ["]	W ["]	H ["]	WT [lb]
71209152	XRW11-1221	3	0.001	7 x 9	15.0	11.6	7.5	12.5
71209153	XRW11-2221	6	0.002	7 x 9	15.0	11.6	7.5	12.5
71209154	XRW11-3221	15	0.005	7 x 9	15.0	11.6	7.5	12.5
71209155	XRW11-4221	30	0.01	7 x 9	15.0	11.6	7.5	12.5